

Solutions that shine.



Yealink MP56 (E2)

Quickstart Guide

www.sunwire.ca

Thank You for Choosing Sunwire!

We pride ourselves on delivering the best service.

Contents

| | |
|---|----|
| Phone Overview with Key Descriptions..... | 2 |
| Assembling Your Phone..... | 5 |
| Setting Up Your Voicemail..... | 6 |
| Navigating Your Voicemail..... | 7 |
| Most Common Phone Features..... | 8 |
| Telephone Feature * Codes..... | 11 |
| Microsoft Teams Integration..... | 12 |

Yealink MP56 (E2)

Overview with Key Descriptions

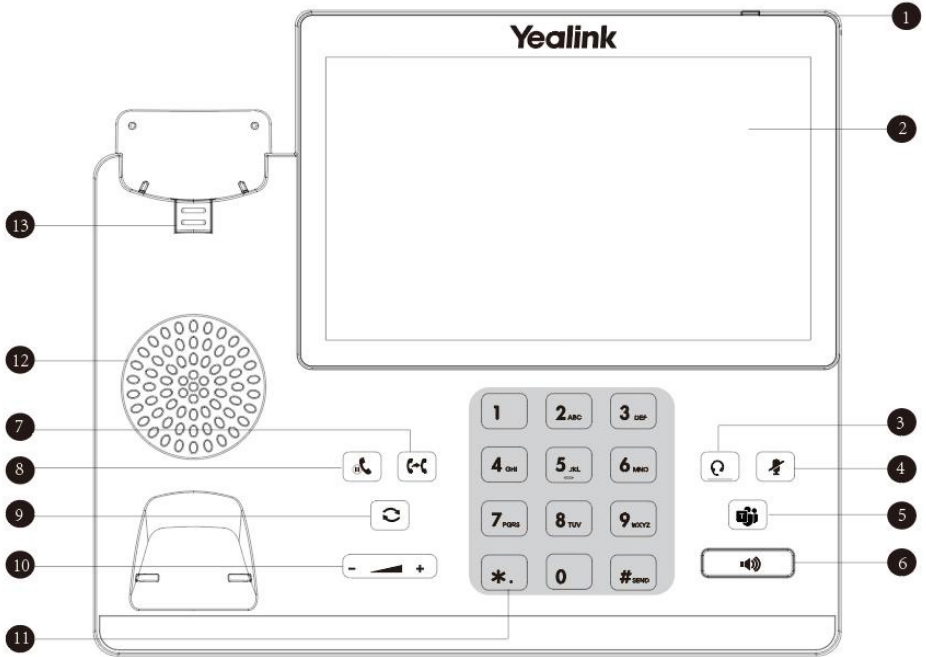

1. **Power Indicator LED:** Indicate phone statuses.
2. **Touch Screen:** 7 inches (800 x 480) capacitive (5 points) touch screen, tap to select items and navigate menus.
3. **HEADSET Key:** Enable you to place and receive calls through a headset. The LED indicator glows green when the headset is activated.
4. **MUTE Key:** Mute local audio during calls and conferences. The LED indicator glows red when the mute feature is activated.

5. **Teams Key:** Returns to the Teams Home Screen.
6. **Speakerphone Key:** Enable you to place and receive calls using the speakerphone. The LED indicator glows green when the speakerphone is activated.
7. **TRANSFER Key:** Transfer a call.
8. **HOLD Key:** Place a call on hold or resume a held call.
9. **REDIAL Key:** Redial a dialed number.
10. **Volume Key:** Adjust the volume of the handset, headset, speaker, or ringer.
11. **Keypad Keys:** Enable you to enter numbers, letters, and special characters.
12. **Speaker:** Provide audio output during hands-free.
13. **Reversible Tab:** Secure the handset in the handset cradle when the phone is mounted vertically.

Assembling Your Phone

1. Connect Cables

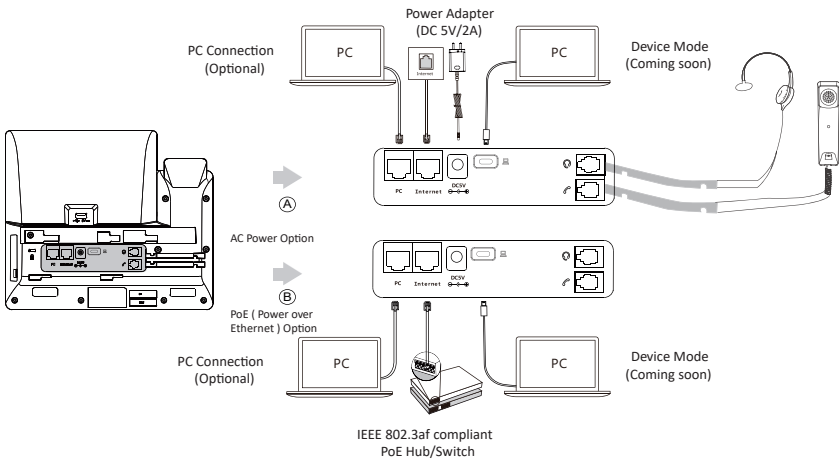

2. Attach the Stand

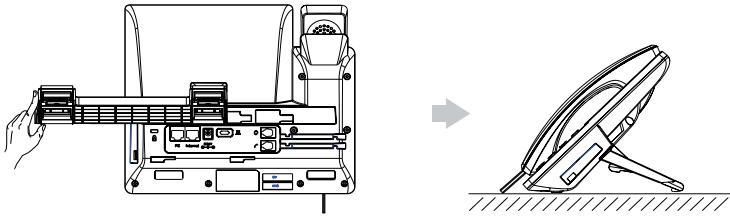

Optional: Attach the wall mount bracket:

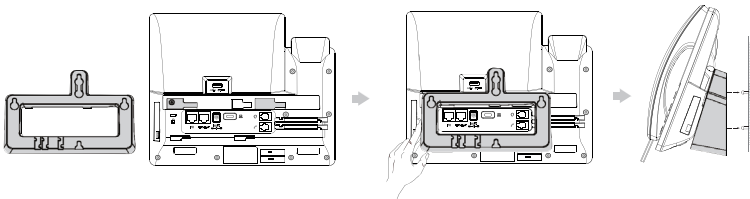

Setting Up Your Voicemail

Choose a passcode and record your greetings.

Accessing your Voicemail

By default, your voicemail is set to answer after 5 rings. To access your voicemail, dial ***98**. To access another extensions voicemail, dial ***98+Ext**. To access your voicemail remotely, call your extension and press the * key when your voicemail answers.

Setting your Passcode

When accessing your voicemail, you are prompted for a passcode. The default passcode is 1234. Once logged in, you can change your passcode by pressing **0** for Mailbox Options and then **1**.

Recording your Greetings

Sunwire offers the option for up to three different types of greetings.

Unavailable Greeting

To record your main Unavailable Greeting, from the voicemail's main menu **press 3** for Greetings then **press 1** to Record a Greeting. **Press 2** to record your Unavailable Greeting and follow the voice prompts.

Busy Greeting

If you would like a different greeting to be played when you are on the phone and your line is busy, you can record a Busy Greeting. From the main menu, **press 3, 1, 1** to record your Busy Greeting.

Temporary Greeting

You can also setup a Temporary Greeting if you are going away but do not want to record over your existing greetings. Once enabled, the Temporary Greeting will always play until it is disabled.

To record a temporary greeting, **press 3, 1, 3** from the main menu.

To toggle (enable/disable) your temporary greeting, **press 3** then **4**.

Navigating Your Voicemail

See the big picture behind your voicemail system.

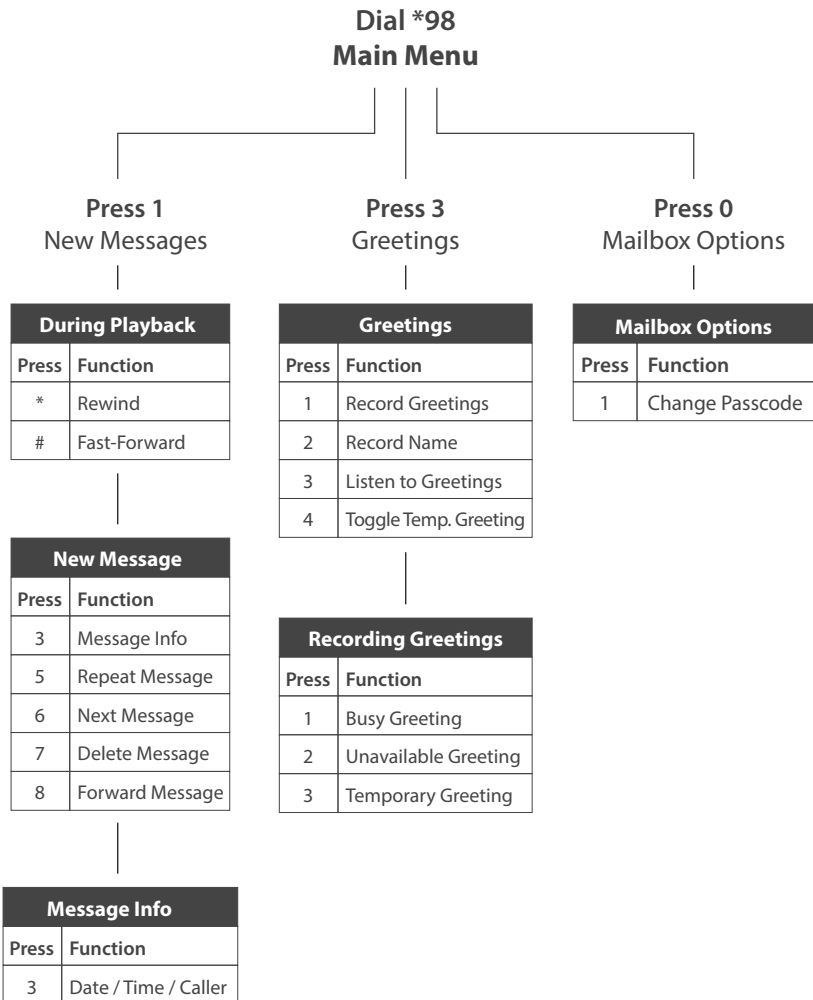

Most Common Phone Features

Learn how our most common features work.

Log In / Log Out of your Extension

This feature is most commonly used by individuals who share phone sets or those who wish to use their extension on different phones (and/or locations).

You can use *11 to log into your extension and *12 to log out of your extension. Dial *13 to playback the phone's current extension status.

People and Speed Dial

Pressing the People key will give you the option to navigate your Teams Contacts.

Your Speed Dial settings can be added and managed from either your telephone set or the administrative web portal. Speed dials can range from 1 to 999; all speed dials are preceded by '0'.

To configure your extension's speed dial settings:

1. Dial: 00
2. Enter the speed dial number you'd like to edit followed by the # key.
3. Enter the phone number to be assigned for this speed dial option.
4. You will hear a recording state: "Speed Dial Saved."

If you select a speed dial which already has an entry; you will be given the option to: edit the entry, delete it or playback its assigned number.

Transferring Calls

There are two methods of transferring a call: Attended (full) Transfer and Blind Transfer. An attended transfer allows you to speak with the individual you are transferring to prior to completing the transfer whereas a blind transfer simply sends the call.

To complete an attended (full) transfer:

1. While on a call, press the Transfer Call key.
2. Enter the number or extension you would like to transfer the call to.
3. Press 'Dial' using the bottom softkeys.
4. You will then be connected with the person you are transferring to while the current call is placed on hold.
5. To complete the transfer, simply press the Transfer Call key again.

To complete a blind transfer, follow the same steps as above but rather than pressing 'Dial' at step 3 - simply press the 'Transfer Call' key again to complete the transfer.

Note: If you transfer a call and it is not answered, it will go to that extensions voicemail. You can also transfer a call using the Directory Listing key rather than entering a number or extension.

Conference Calling

The Conference Call (3-way) key allows you to add a third person to the call. It's functionality is the same as an attended transfer, although rather than completing the transfer it merges all the callers.

Note: Like an attended transfer, you must first speak to the person you are inviting into the conference call. There is no 'blind' conference call. Also, because you initiate the conference call, hanging up on the other users will drop the call completely. To avoid this, rather than hanging up the call, use the 'Leave' button which will appear as a bottom softkey during a conference call.

Parking a Call

Inbound calls can be parked (put on a public hold) by dialling: ##. Parking a call allows you or another user to pick up the call from any other device on the phone system.

While on a call, you will find a 'Park' softkey. If your phone is not equipped with a 'Park' softkey, simply press ##. This will place the call in the next available parking lot. The system will read back the parking lot number once the call is parked.

The call will then leave your phone and you can hang up the receiver.

You could now advise the person who must answer the parked call that they have a call parked on "XX" (where XX represents the parking lot number where the call was parked).

Users can simply dial the parking lot number in order to pickup the parked call.

Telephone Feature * Codes

Access features quickly using the following dial codes.

| | Dial Code |
|-------------------------------|-----------------|
| Access Voicemail | *98 |
| Anonymous Calling | *67 + Number |
| Call Forwarding Enabled | *72 + Number |
| Call Forwarding Disabled | *73 |
| Park Call | ## |
| Answer Parked Call | Dial Lot Number |
| Extension Login | *11 |
| Extension Logout | *12 |
| Extension Login/Logout Toggle | *904 |
| Extension Status | *13 |
| Record Call (if purchased) | #1 |

Microsoft Teams Integration

See how this phone integrates with MS Teams.

Home Screen

You can enable the home screen on your phone. The Home screen is displayed after the phone startup.

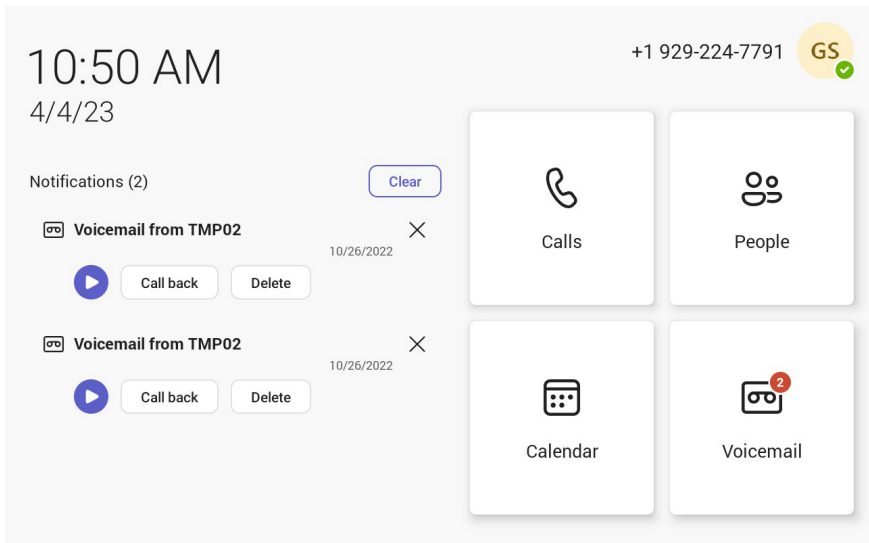

Access the Calls Screen

The Calls screen is displayed after the phone startup if you do not enable the home screen. You can place a call from the history entry or view the favorites information from the Calls screen.

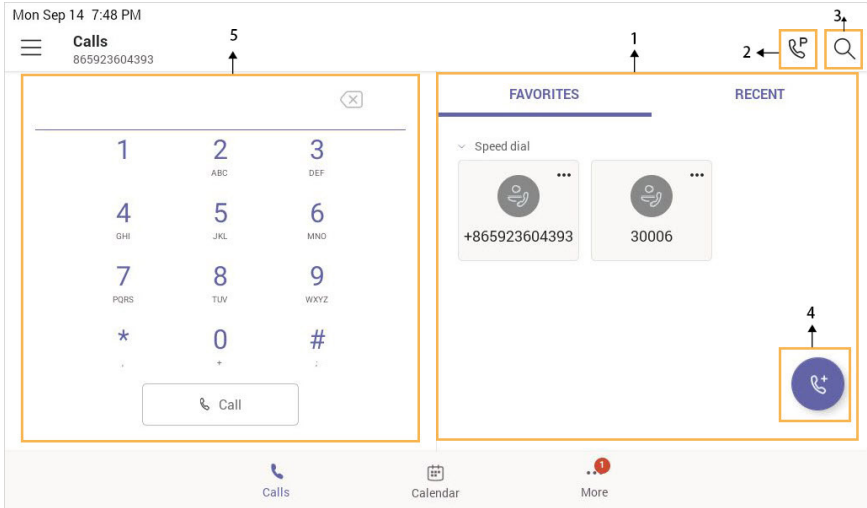

1. FAVORITES & RECENT:

FAVORITES: Displays favorite contacts.

RECENT: Displays recent calls.

Display the detailed information of the contact.

2. **Call Park icon:** Tap to retrieve a parked call.
3. **Search icon:** Tap to search for a contact.
4. **New Call icon:** Tap to initiate a call.
5. **Dial Pad:** Enter numbers.

Access the Calendar Screen

You can access the Calendar screen to join or schedule meetings. Tap Calendar on the screen.

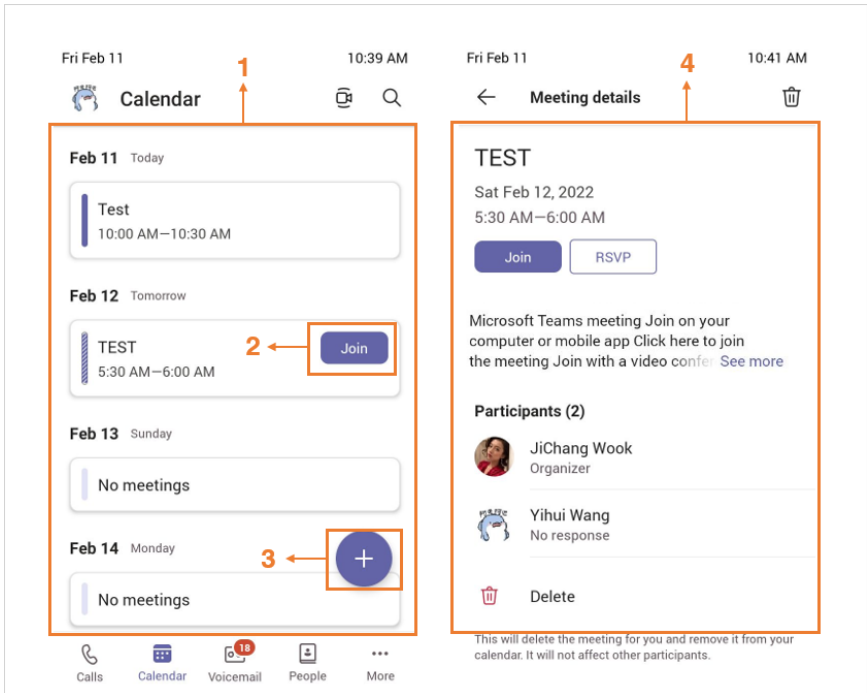

1. **Scheduled meeting list:** Display all the scheduled meetings on the Teams phone, from the Teams client, or Outlook.
2. **Join button:** Tap to join the corresponding scheduled meeting.
3. **Add/New icon:** Tap to schedule a meeting.
4. **Meeting Details:** Tap the corresponding scheduled meeting to view the meeting details.

Access the People Screen

You can access the People screen to manage all your contacts. Tap More > People.

Solutions that shine.

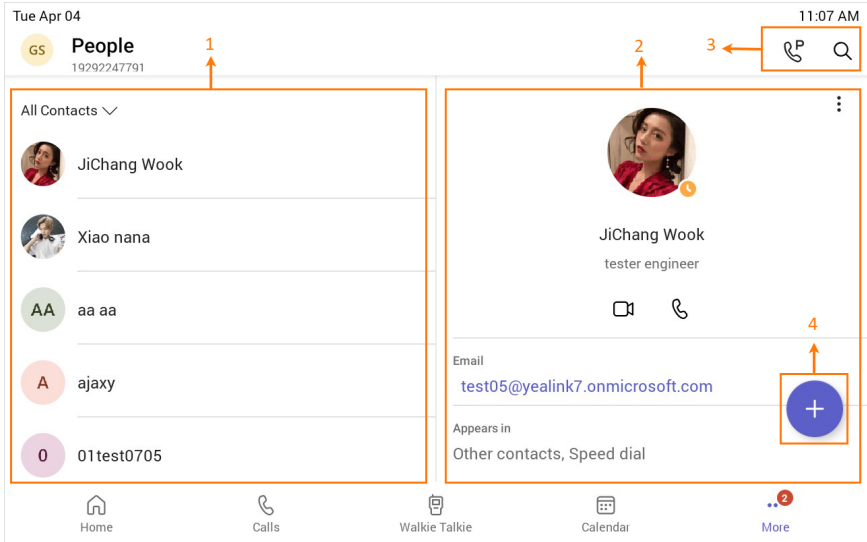

- 1. Contacts list:** Display all the contacts on the phone or contacts in a specific group.
- 2. Contact details:** Tap the corresponding contact to view the contact details.
- 3. Operation:**
 - Tap the Magnify Glass/Search icon to search for a contact.
 - Tap the Call Park icon to pick up a parked call.
- 4. Add/New icon:** Tap to create a new group or add contacts from the directory.



Sunwire Inc.
www.sunwire.ca

If you require any further assistance,
please contact our support team:

tier2@sunwire.ca
1-833-727-6777

Proudly Canadian 